



FEATURES AND BENEFITS OF THE TURNCRAFT® COMPOSITE RAILING SYSTEM

- High-performance composite material offers durability, resistance to weather and fewer maintenance requirements.
- PVC Capstock exterior gives a painted wood-like appearance without the upkeep of natural wood. No annual staining or sealing required.
- Composite materials are superior to vinyl in every way, including looks and durability.
- Delivered in boxed kits complete with all the materials you need for installing between posts.
- Material is resistant to warping, splitting or splintering for safe and worry-free use.
- Routed system creates an attractive appearance without exposed fasteners.
- Multiple designs and colors allow you to meet your style and aesthetic desires.
- Limited Lifetime Warranty protects your investment.
- Material cuts like wood, so no special tools are needed... great for rail renovations.
- Composite material resists water, insects and termites for long-lasting appearance without additional annual maintenance expenditures.
- Third party testing to meet ICC-ES AC174 requirements.
- 6' and 8' horizontal rail lengths offer increased renovation and design capabilities.
- Professional contractors report 50% faster installation times over other railing systems.

| Turncraft Poly-Classic Composite Railings | | | |
|--|---|---|---|
| Benefit | C | V | W |
| Beautiful Look and Feel of Painted Wood | ✓ | | ✓ |
| Structural Integrity | ✓ | ✓ | ✓ |
| Quick & Easy Installation, Routed System | ✓ | ✓ | |
| Fewer Inserts During Installation* | ✓ | | |
| No Exposed Hardware | ✓ | ✓ | |
| Limited Lifetime Warranty | ✓ | ✓ | |
| Least Likely to Expand and Contract* | ✓ | | |
| Weather Resistant | ✓ | ✓ | |
| Resists Warping, Rotting, Splitting, Peeling and Splintering while Retaining Color | ✓ | ✓ | |
| Resists Water, Insects and Termites | ✓ | ✓ | |
| Little to No Annual Maintenance | ✓ | ✓ | |
| Multiple Colors and Designs | ✓ | ✓ | |
| Passed Third Party ICC-ES AC174 Testing | ✓ | | |

C= Poly-Classic Composite, V=Vinyl, W=Wood

*Typically, but not always

COLORS

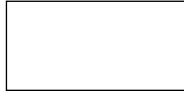

WHITE

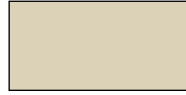

KHAKI

STAIR RAIL APPLICATION

FAST AND EASY INSTALLATION

Stair rail applications are available in 6' spans for all three styles. Newel posts, rails and balusters are made from durable composites with the look of wood.

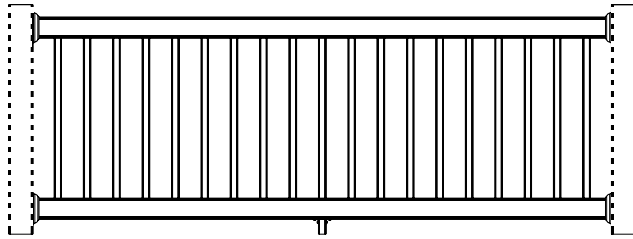
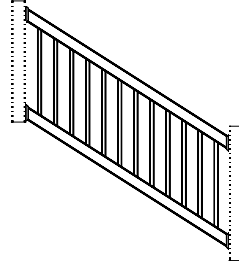

CRAFTSMAN AND COLONIAL KITS INCLUDE

| QTY | DESCRIPTION | NOTE: |
|-----|---|---|
| 2 | Composite Rail | The Craftsman Over-The-Post kit is a Craftsman kit with a cap rail that is available in both 13' and 17' lengths. All required brackets are included in the standard Craftsman kit. |
| 19 | Composite Balusters (8' kit)* | |
| 1 | Aluminum Insert | |
| 4 | Composite Rail Bracket with Screws | |
| 1 | Composite Foot Block Kit | |
| 1 | Touch-Up Paint | |
| 2 | Saddle Bracket with Screws (used if applying Top Cap Rail only) | |
| 1 | Set of Application Instructions | |

*6' kit contains 14 balusters

ACCESSORIES

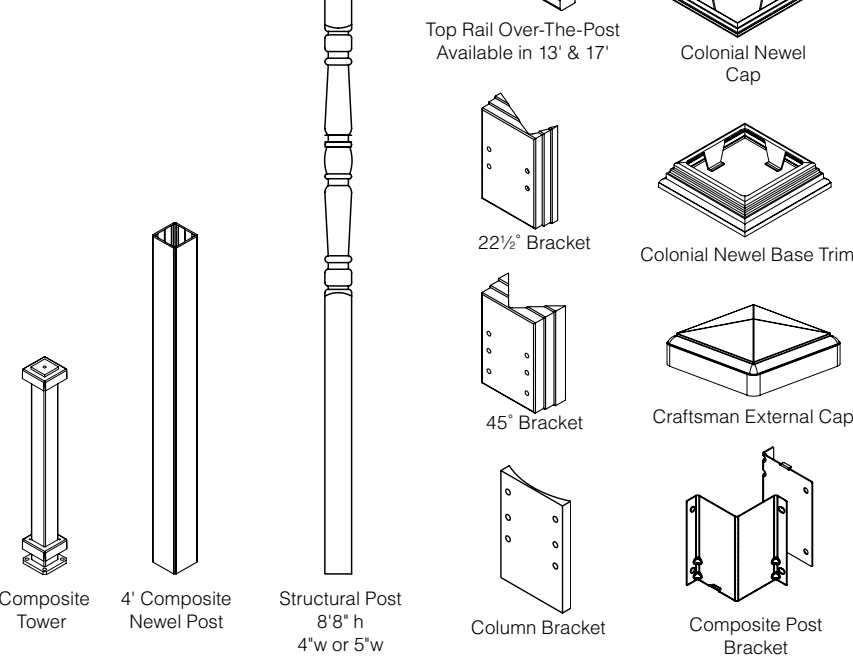

EVERYTHING YOU NEED FOR A QUALITY LOOK.

The routed system offers an attractive finished look without exposed fasteners. Routed holes and precision manufacturing assures that parts fit together tightly for a solid feel—and quality appearance. Plus it is available in 6' and 8' spans to meet your design requirements.